

PLANT VIEW
VISTA SUPERIOR

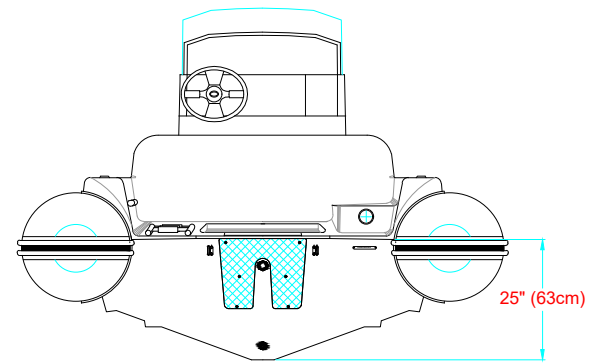

AFT VIEW
VISTA TRASERA

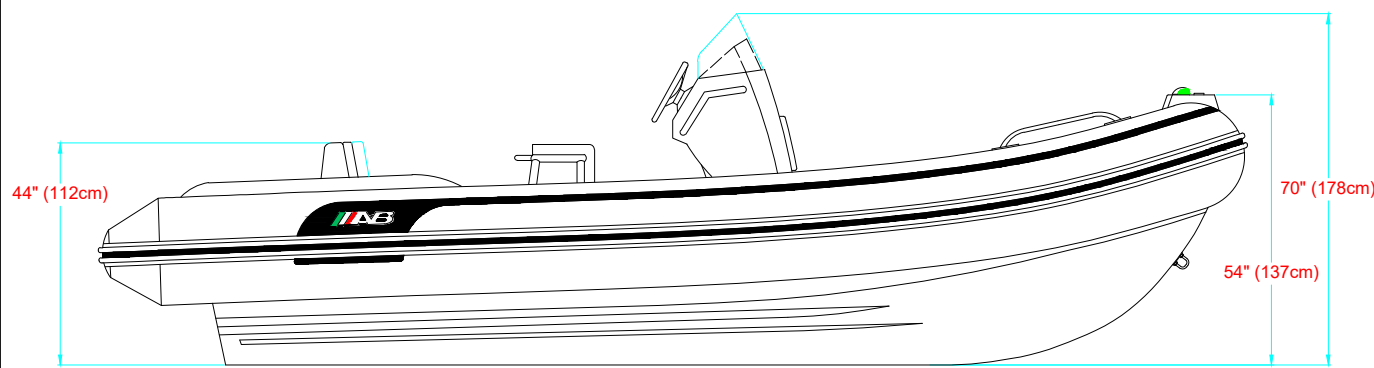

LONGITUDINAL PROFILE
VISTA LATERAL

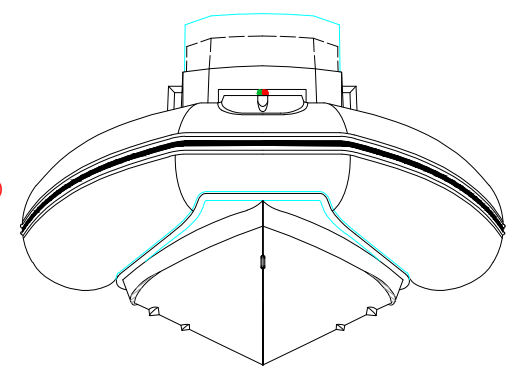

FORE VIEW
VISTA FRONTAL

MAIN PARTICULARS

MAXIMUM LENGHT/ESLORA MAX. _____ 19' (5.79m)
 MAXIMUM BEAM/MANGA MAX. _____ 8' 4" (2.53m)

NOTES: 1.-ALL DIMENSIONS IN INCHES & CENTIMETERS
 TODAS LAS MEDIDAS ESTAN DADAS EN PULGADAS Y CENTIMETROS

		TITLE: " OCEANUS 19 VST " GENERAL ARRANGEMENT ARREGLO GENERAL						
SUBJECTED: JAIRO MARTINEZ				DATE: 09.02.24				DRAWN: HECTOR SUAREZ
APPROVED: HERMES GARCIA		SCALE:	SHEET: 1/1	CODE:	PLAN:	No.REV: 6	DATE:	APPROVED: